

WATER WALL PREMIUM

Manual

Water Wall Premium developed by a team of Polish designers is the perfect decoration for indoor and outdoor environment. This product was specially designed for prestigious and luxurious venues.

The presence of water always has positive impact on human's life and well-being. The water flowing in water wall increases air humidity and introduces a favorable microclimate. The water wall can be located in interiors such as private houses, public places as shopping malls and the offices of big companies.



INDEX

1. Description	2
2. Technical drawing	2
3. Components	3
4. Packaging and unpacking guidelines	4
5. First launch instructions	8
6. Smart plug mobile app	11
7. Maintenance guide	12

1. DESCRIPTION

Water Wall Premium is made from high quality materials.

It is very corrosion resistant and easy to clean. Water Wall Premium is equipped with wheels in order to make it comfortable to move. What is more, the glass panel has LED lightning installed along the glass panel, which makes the water wall unique.

The color of LED lighting can be controlled using a remote control.

Technical data:

Total height: 1980 mm
Total length of the base: 1030 mm
Total width of the base: 450 mm

Width of the glass panel: 890 mm
Thickness of glass panel: 5 mm

Weight of glass panel: 35 kg
Weight of base: 50 kg
Weight of stones: 11 kg
Total weight: 96 kg

The capacity of reservoir: 150 L

2. TECHNICAL DRAWING

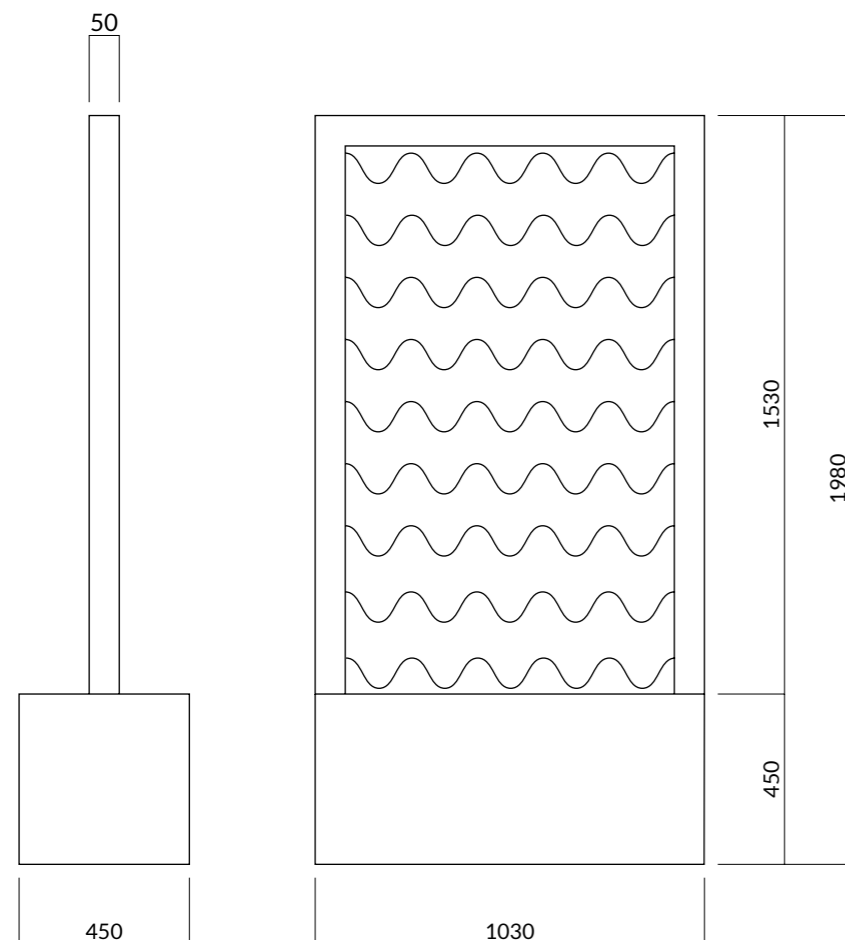

3. COMPONENTS

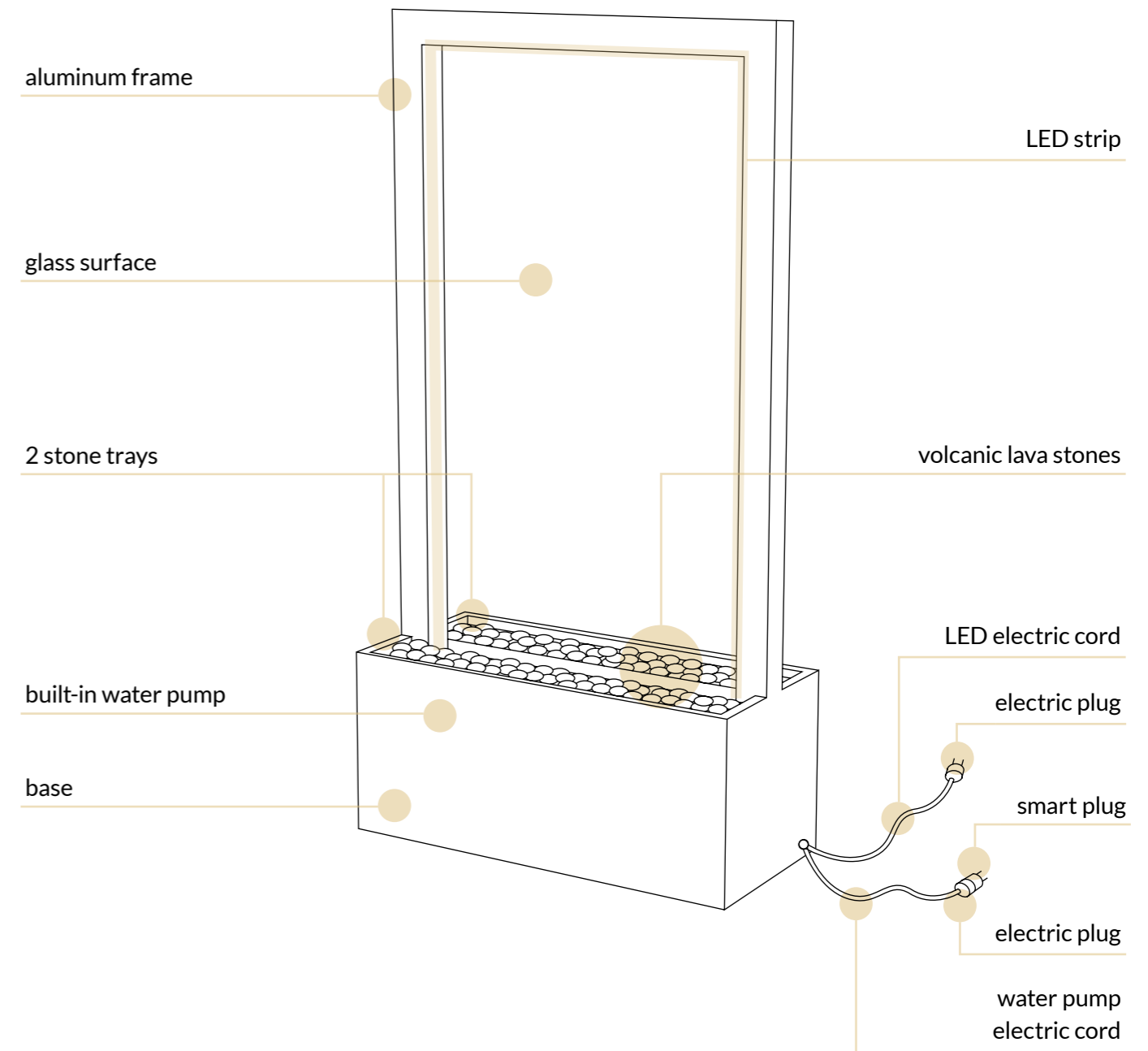

4. PACKAGING AND UNPACKING GUIDE

STEP 1.

Water Wall Premium will arrive on a plastic pallet.

When packed it is secured with cardboard, styrofoam, bubble wrap and stretch foil.

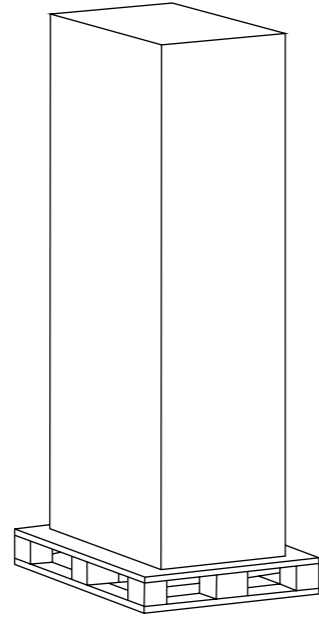

STEP 2.

Unpack the fountain.
Warning! There is no box underneath the Water Wall.
Do not cut the cardboard box! Cutting the cardboard might damage the product inside. Lift the box.

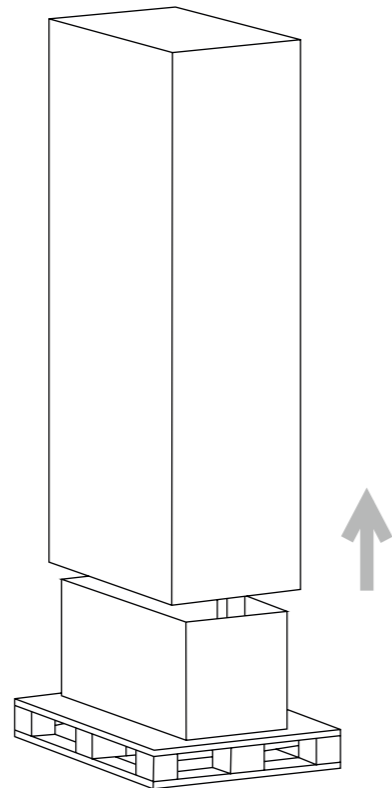
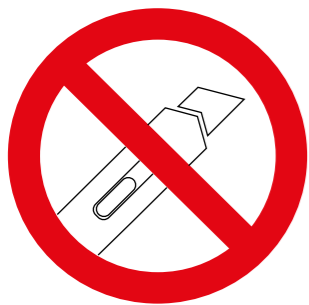

STEP 3.

Remove the cardboard box.

Remove styrofoam securing the glass surface.

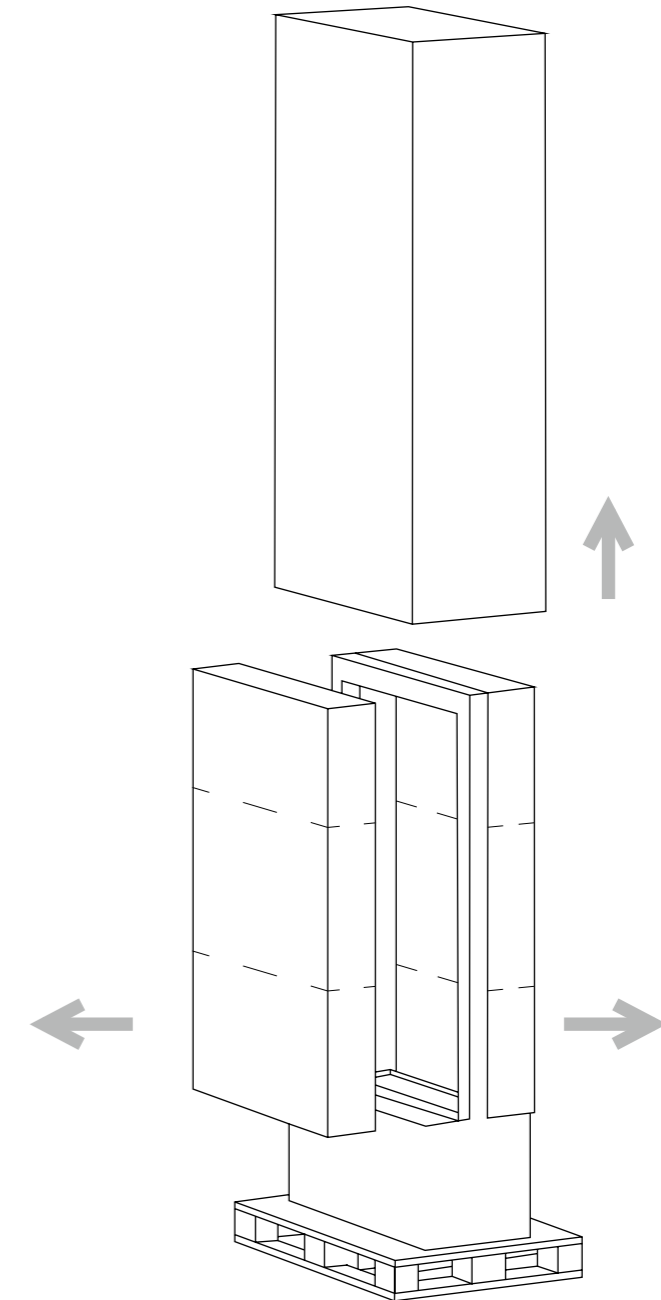

STEP 4.

Gently move Water Wall from the pallet.
Lift the fountain holding the frame, not the bottom of the product.

Warning: the fountain is heavy, make sure to lift it properly.

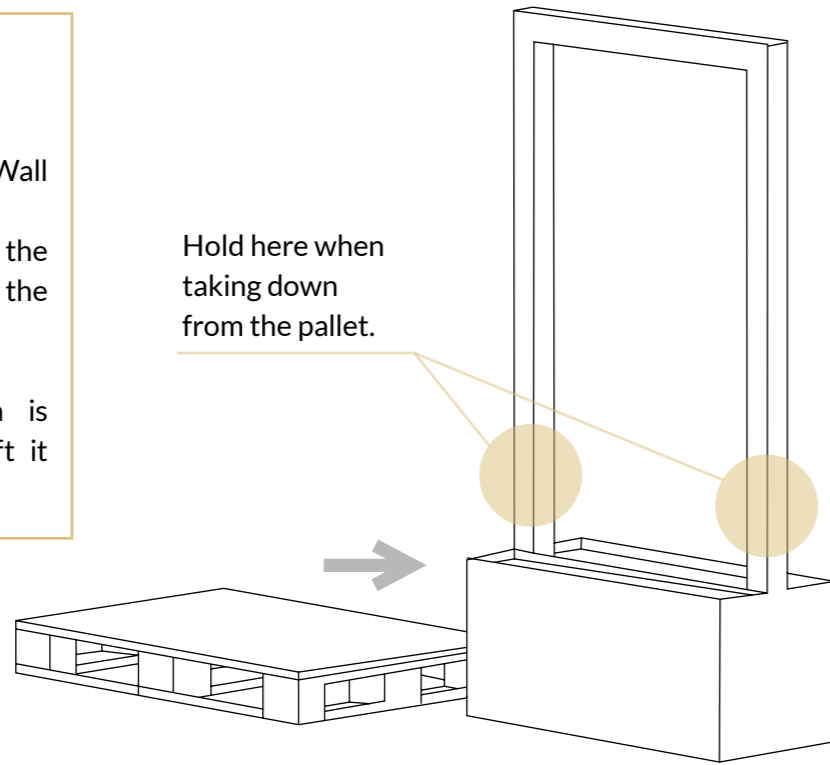

STEP 5.

Lift the stone tray and take out 3 boxes from the inside.

Unpack the boxes.

a. The biggest box contains 11 kilograms of volcanic lava stones.

b. The flat box contains USB drive and remote control.

c. The smallest box contains the smart plug.

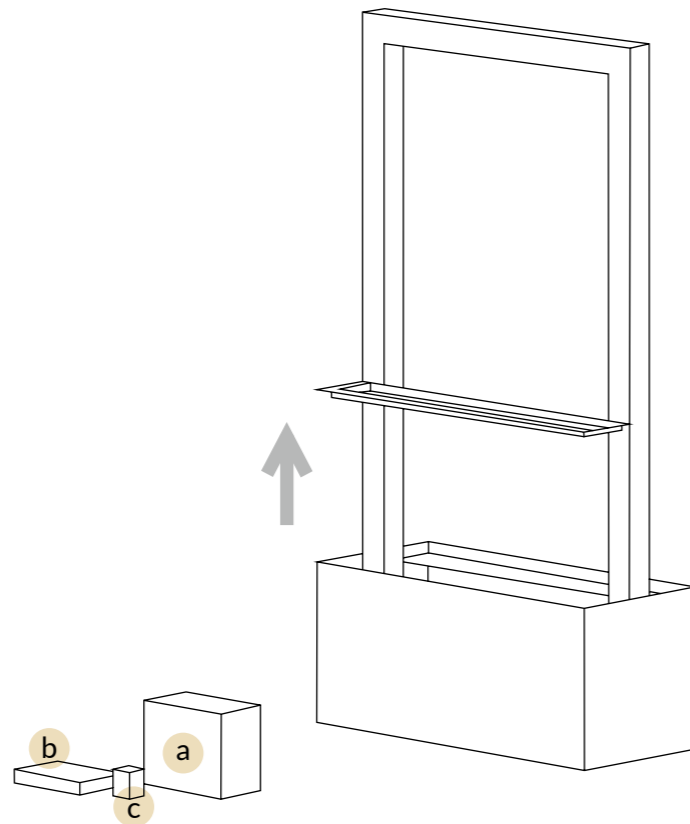

STEP 6.

Follow the next few steps to take out additional styrofoam securing Water Wall.

a. Loosen the screws on each side of the frame.

b. Lift the water tank cover.

c) Remove styrofoam placed between water tank and its cover.

d. Take out the styrofoam cube.

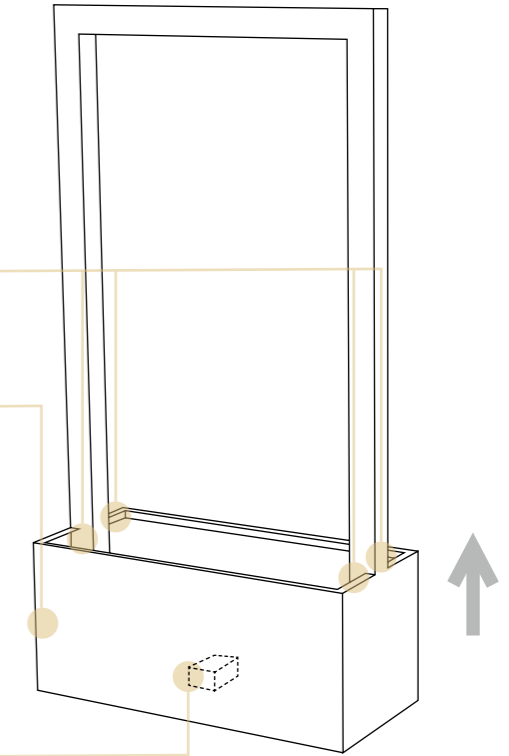

STEP 7.

a. Put the water tank cover down in its correct place.

b. Screw back the screws to secure the water tank cover.

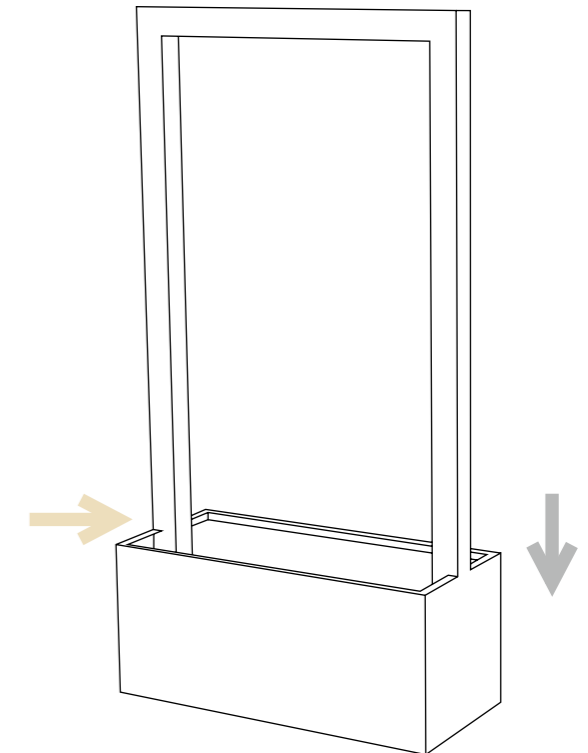

5. FIRST LAUNCH INSTRUCTIONS

STEP 1.

Fill the base container with 150 L of water.

Fill with water up to the level marked inside the reservoir.

CAUTION!

Do not let the pump to work dry!

Do not plug in the fountain before filling the tank with water first.

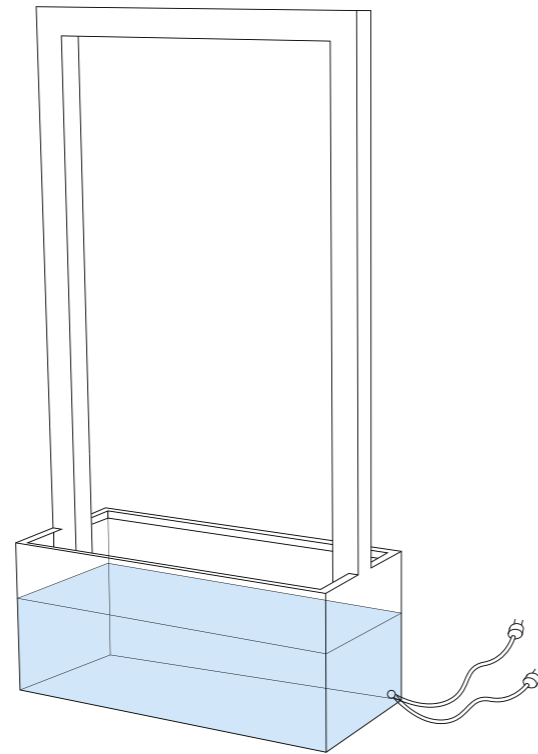

STEP 3.

Place stones on two trays.
Distribute the stones evenly.

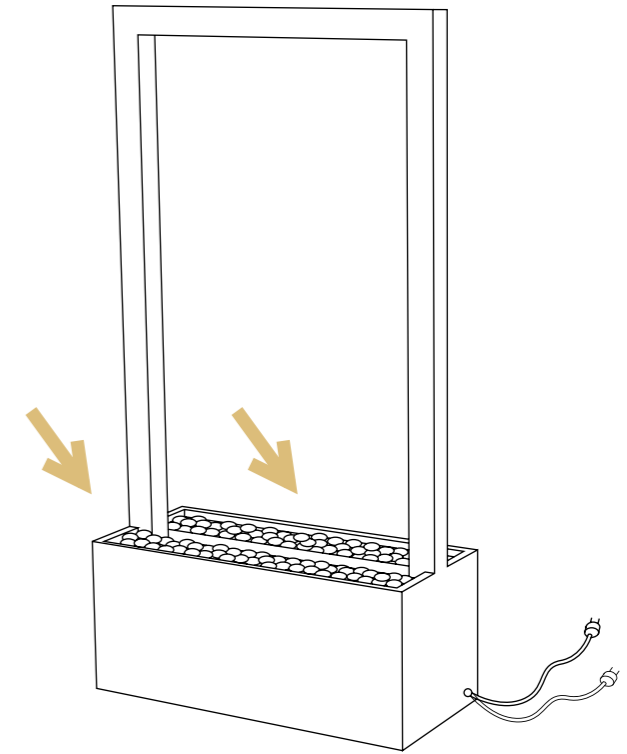

STEP 2.

Put back 2 stone trays on each side of the fountain.

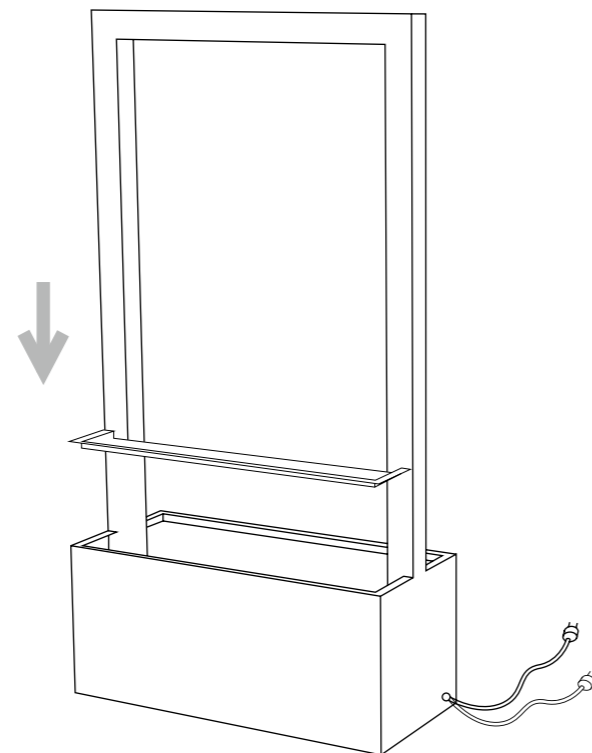

STEP 4.

Unpack AZzardo smart plug from the box.

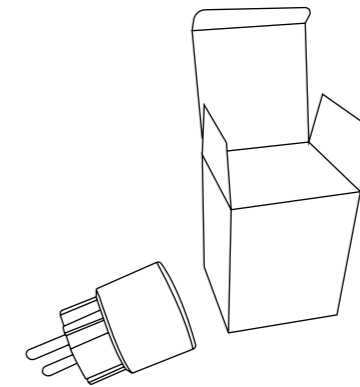

STEP 5.

Connect water pump electric plug with AZzardo smart plug.

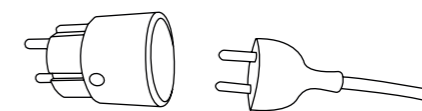

STEP 6.

Connect both electric cords of the Water Wall to the power source.

CAUTION!
Do not let the pump dry!
Do not plug in the fountain before filling the tank with water first.

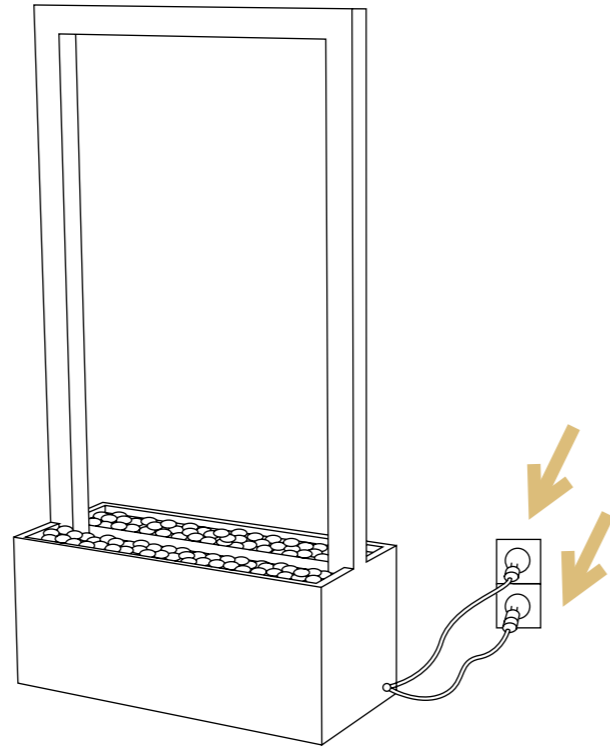

STEP 7.

Once the fountain is plugged, the color of LED strip can be controlled using the attached remote control.

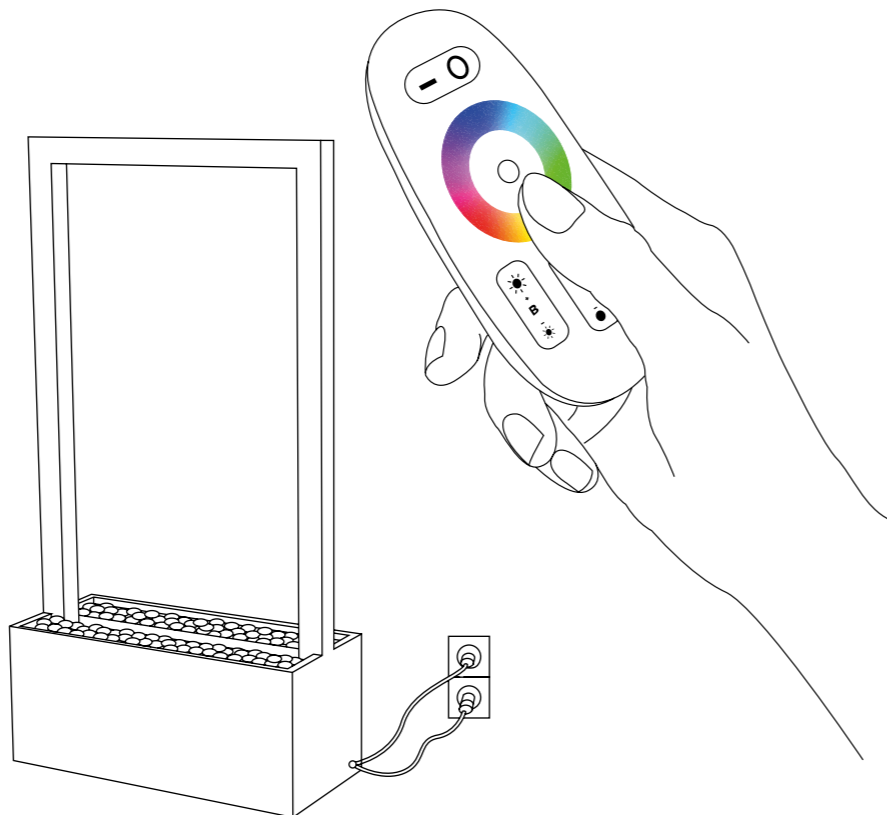

6. SMART PLUG MOBILE APPLICATION

Water Wall Premium is equipped with a smart plug which will allow you to control your product easily and quickly.

Using AZzardo Smart system you can manage the product using your mobile phone. Make your Water Wall automatic.

Take advantage of wide possibilities of smart solutions which can be personalised serving your needs and preferences well.



ACCOUNT REGISTRATION MANUAL

1. Download and install mobile application AZzardo Smart available for free in Google Play / App Store or scan the QR code below.



2. Open AZzardo Smart app and choose REGISTER, accept Privacy policy.

3. Choose suitable country code and enter your email address.

4. Once you enter your details you will receive verification code, enter the code in the app.

5. Set your access password.

6. Press CREATING HOME on the main screen.

7. Fill place name and location, press ready in the top right corner of the screen.

8. Now you can use the application in full capacity.

CAUTION!

Always unplug the pump from the electrical outlet before cleaning & handling.
Disconnect and store the unit in a dry place if not in use for an extended period of time.
Do not operate with water above 90°F or 30°C. Do not lift, carry or pull the pump by the power cord. Do not exceed the maximum voltage & wattage on transformer.
DO NOT ALLOW THE PUMP TO RUN DRY.

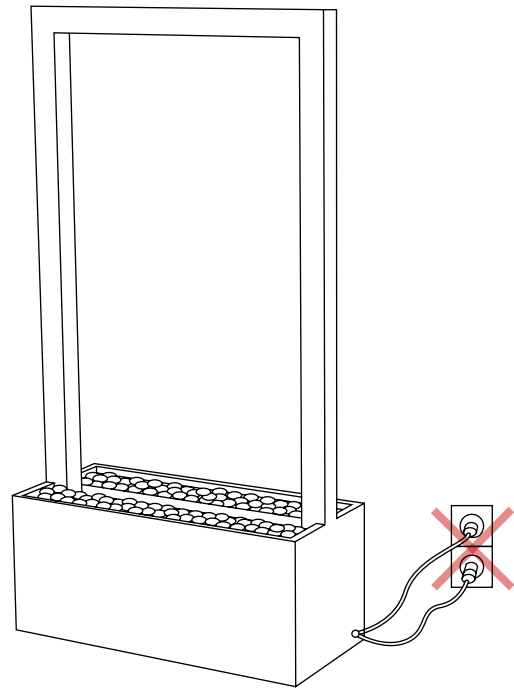

RECOMMENDED HOURS OF OPERATION:

We recommend that you allow your water feature to operate 24 hours a day.

RESERVOIR:

Clean the inside of the reservoir thoroughly with a cloth every 6 months or as needed.

DISTRIBUTION BAR:

Should be removed, inspected and cleaned every 6 months or as needed.

GLASS:

It is recommended to wash the glass at least once every 2 weeks.

CHANGING / ADDING WATER:

It is highly recommended that you add distilled water to the reservoir as needed. If you choose not to use distilled water, using a totally organic algae removing and preventative additive, in conjunction with an all natural mineral deposit preventative additive, together will keep your water wall running clean.

SAFETY:

It is always recommended that the water wall uses a surge protector or a Ground Fault Circuit Interrupter GFCI.

For more information please contact:

www.gardenspot.eu

